

---

# Table of Contents

## Electronic Dampening Control (EDC)

Subject	Page
<b>Purpose of the System</b> .....	<b>3</b>
<b>System Components E38</b>	
<b>System Components E31/E32</b>	
Acceleration Sensors .....	6
Steering Angle Sensors .....	6
Control Module .....	7
Program Switch .....	7
Road Speed Input .....	8
Solenoid Controlled Dampers .....	8
<b>Basic Damper Operation</b> .....	<b>9</b>
E38 Damper Operation .....	10
E31/E32 Damper Operation .....	11
<b>I-P-O E38</b> .....	<b>12</b>
<b>I-P-O E31/E32</b> .....	<b>13</b>
<b>Electronic Damper Control Functions</b> .....	<b>14</b>
<b>Safety Monitoring</b> .....	<b>16</b>
<b>Special Tools</b> .....	<b>17</b>

---

**Model:** E31 850i, 850Ci, 850CSi, 840i 1991-1997  
E32 750iL, 735i/iL, 740i/iL 1988-1994  
E38 750iL, 740i/iL from 1995-2001

**Production:** All with EDC

**Objectives:**

After completion of this module you should be able to:

- Identify EDC System Components
- Locate EDC System Components
- Understand EDC System Operation

---

## Purpose of the System

The EDC III is a fully automatic adjusting damper control system available on the E31, E32 and E38 vehicles. It also allows the driver to choice of two damping programs (comfort and sport)

Conventional non-adjustable systems have damper (shock absorber) settings which provide an acceptable damping action over as wide of range of speeds and loads as possible. This means a compromise between a high standard of ride comfort on one hand, and a margin of safety on the other.

Modern technology enables this trade off to be resolved with variable damping, and this principle has been adopted on the EDC III system.

The system uses various input parameters directly relating to road condition, load on the car and driving style to select one of three damping characteristics, (soft, medium or hard).

The result is optimum damping over a wide range of speeds and loads, and definite gains in both ride comfort and safety.

EDC III is a further development of the variable damping systems already used on BMWs in other markets.

The purpose of any damping force adjustment is to reduce oscillations as perceived by the car's occupants, without affecting either handling or driving safety.

This is achieved by continuously matching the damping force to road conditions, vehicle load and driving style.

## System Components E38

The EDC system on the E38 consists of the following components:

- **Front-axle acceleration sensor** - This is installed on the right side of the wheel housing, close to the right-hand upper spring strut mount.
- **Rear-axle acceleration sensor** - This is installed on the right rear wheel arch, on top of the spring strut mount
- **EDC III control module** . Mounted on right side of trunk. (Behind Glovebox from 99 Model Year)
- **Steering angle sensor** - On lower section of steering column
- **Solenoid valves** - Integrated in the strut housing.
- **Program switch** - Located on dash in center below IHKA panel

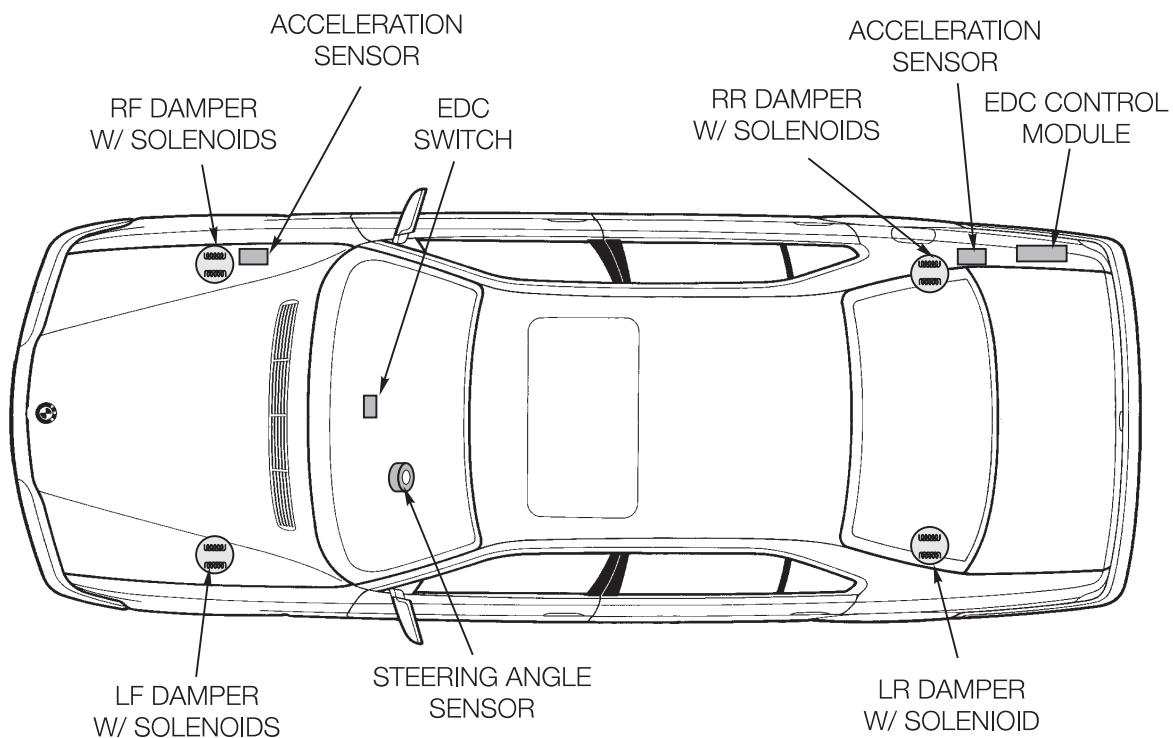

---

## System Components E31/E32

The EDC system on the E32/E31 consists of the following components:

- **Front-axle acceleration sensor** - This is installed on the right side of the wheel housing, close to the right-hand upper spring strut mount.
- **Rear-axle acceleration sensor** - This is installed on the right rear wheel arch, on top of the spring strut mount.
- **EDC III control module and power relay** - Both units are mounted in trunk on right side.
- **Longitudinal acceleration sensor** - On the left rear wheel arch.
- **Steering angle sensor** - On the steering column (similar component on the E31, E32 but not interchangeable)
- **Solenoid valve** - Two valves are mounted at the base of each strut assembly.
- **Program switch** - Located on center console.

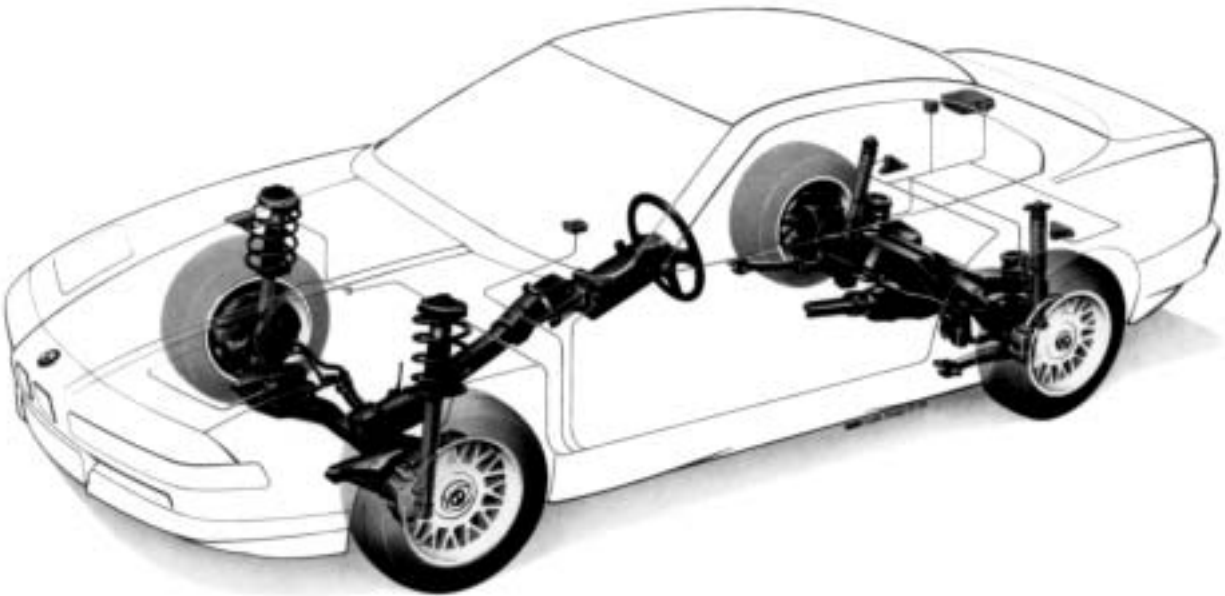

---

## Components

### Acceleration (Motion) Sensors

There are three acceleration sensors: one each for the front and rear axles (vertical motion), and one for forward/aft motion. All sensors are solid state, piezo ceramic elements. Vehicle movement on the sensors is converted into an electric signal. The control module uses these inputs to detect road surface condition, vehicle loading and degree of motion. The loading of the vehicle influences vertical motion and is therefore detected by the sensors.

The E38 acceleration sensors are identical to the E31/E32 sensors, the longitudinal sensor has been deleted on the E38. The dynamic longitudinal forces on the vehicle are calculated from the inputs of the front wheel speed sensors.

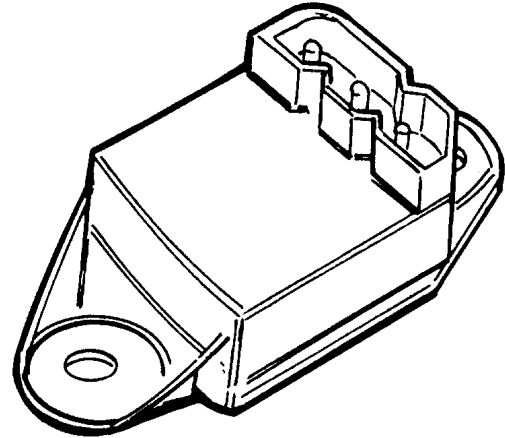

The following inputs are used to detect dynamic forces acting on the vehicle;

- Vertical acceleration
- Fore and aft acceleration
- Steering wheel angle
- Vehicle road speed

### Steering Angle Sensor

The steering angle sensor is identical for all vehicles. The rotating double potentiometer provides two variable resistance signals for turn recognition. The EDC control module used this input to increase the damping rate when cornering.

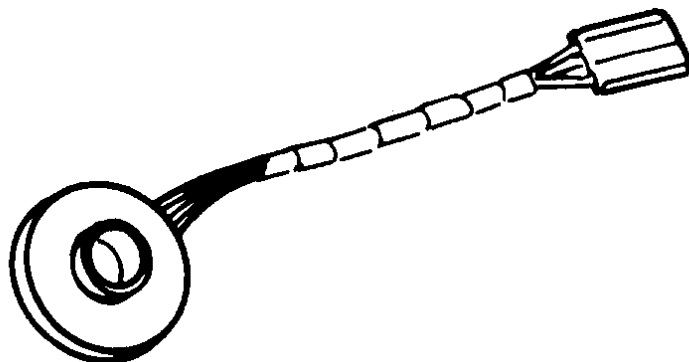

---

## Control Module

One basic control module is used for the E38. Selecting the proper damping curves is carried out via the DISplus or GT-1. The E31/E32 also use a basic control module which must be coded for proper vehicle application. Refer to the EPC for the proper control module.

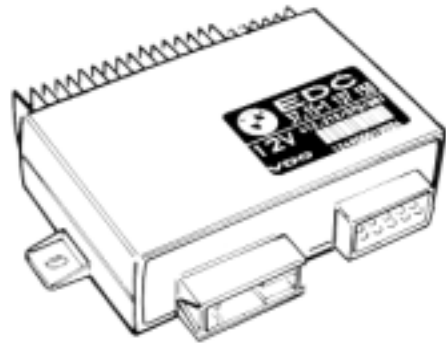

## Program Switch

The E38 uses a momentary switch to select comfort or sport. Low for comfort and high for sport. The E31 and E32 use a two position rocker switch to select comfort or sport.

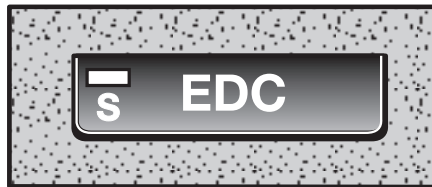

E38

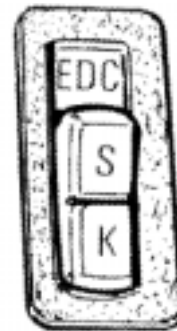

E31/E32

## Comfort Program

When the comfort program is selected, the priority setting is for soft damping. Any changes to dynamic movements detected by the sensor will allow the system to switch to either medium or hard depending on how severe the dynamic changes are. The system will automatically switch back to the soft setting when conditions warrant. This results in an ideal combination of maximum comfort and optimum driving safety.

## Sport Program

When the sport program is selected only the medium and hard damping settings are used. The control unit selects the medium setting until dynamic changes require a higher damping force to maintain stability. The program characteristics allow the hard setting to be selected sooner and held longer than the comfort program.

## Vehicle Road Speed

The road speed comes from the ABS/ASC or DSC control module on the E38.

The E31 signal comes from the EKM and the instrument cluster supplies the signal for the E32.

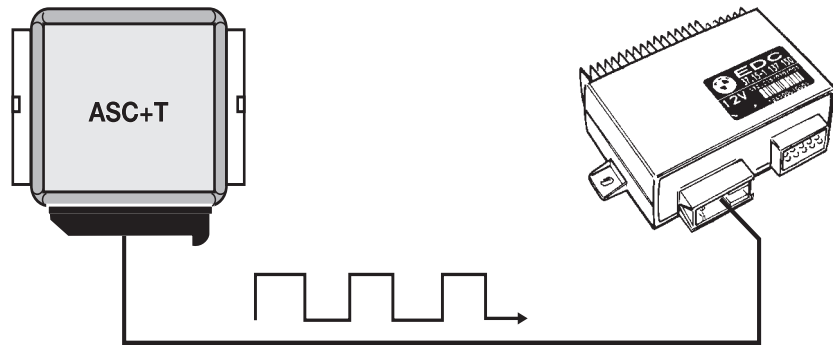

## Solenoid Controlled Dampers E31/E32 and E38

The EDC system utilizes solenoid valves to change the valving in the damper to relieve the oil flow through additional valves and create a softer damper value. The E38 solenoids are mounted internally. The E31/E32 use dampers with the solenoid valves mounted externally of the dampers.

Front axle twin-tube, gas pressurized dampers and rear single tube dampers are used on all EDC vehicles. Two solenoid valves are used for each strut assembly. These valves provide an additional passage for the flow of oil in the soft and medium settings.

Both valves are never energized simultaneously. Damping can be varied front to rear, but not side to side.

E38 wiring for control runs up through piston.

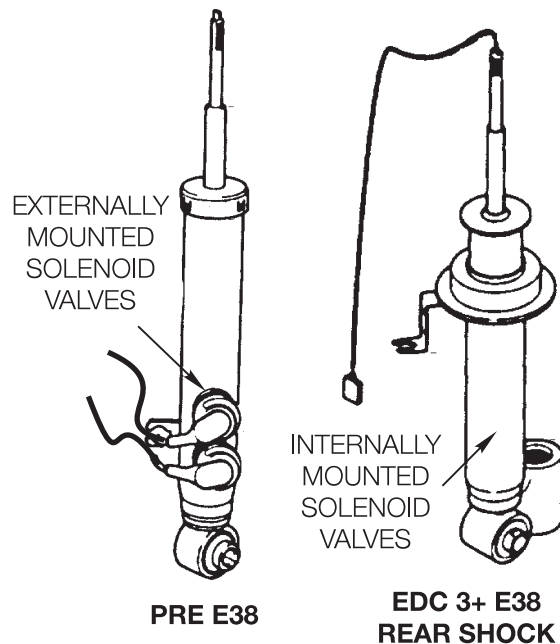



# Basic Damper Operation

When the vehicle bounces the damper travels thru the compression and rebound stages. The damper as illustrated corresponds to the EDC sport damper setting because the oil basic dampers transfer uses only a mechanical one-way valve. The EDC III system can provide softer damping rates (soft, medium) by energizing solenoid valves which allow additional oil volume to transfer.

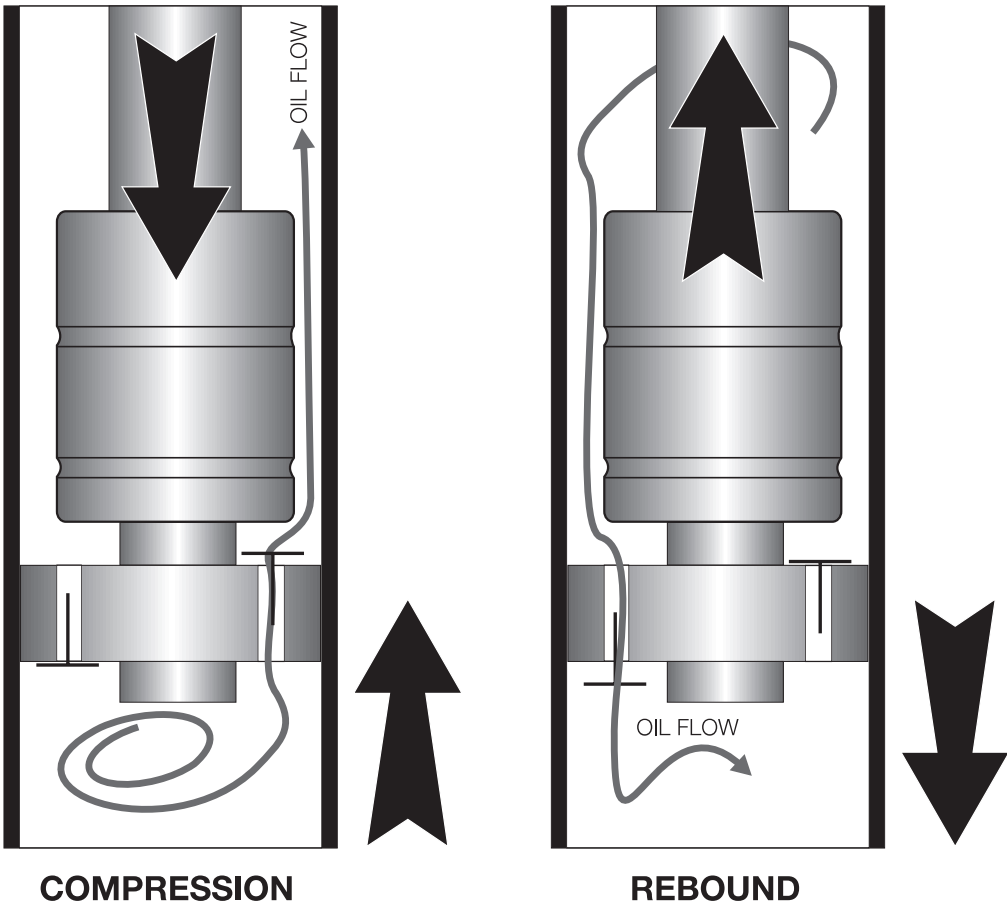

## E38 Solenoid Controlled Damper Operation

There are three passages for oil transfer in the strut assembly. The first is the main oil transfer valve. This valve is always open. The second and third valves are controlled by the EDC solenoids. Through the two different orifices, the solenoids can vary the throughput of hydraulic oil transfer thereby regulating the damping force.

**Soft Setting** - In this setting the “soft solenoid in each shock is energized allowing oil transfer through the mechanical orifice and larger diameter “soft” orifice. The soft setting provides oil transfer with the least restriction and the struts are set to the softest damping force.

**Medium Setting** - When the EDC control module’s processing calls for the medium setting, the soft solenoid is de-energized and the “Medium” solenoid is energized so that the oil now flows through the smaller valved orifice. This restricted oil flow increased the damping force of the strut.

**Hard Setting** - When the EDC control module’s processing requires the hard setting, the medium solenoid is switched “OFF”. This closes the solenoid controlled orifices and only allows oil transfer through the main valve. The struts are now set to the maximum firmness.

This is also the failsafe setting of the EDC III system. With no power applied to the struts, the system will be in the hard setting.

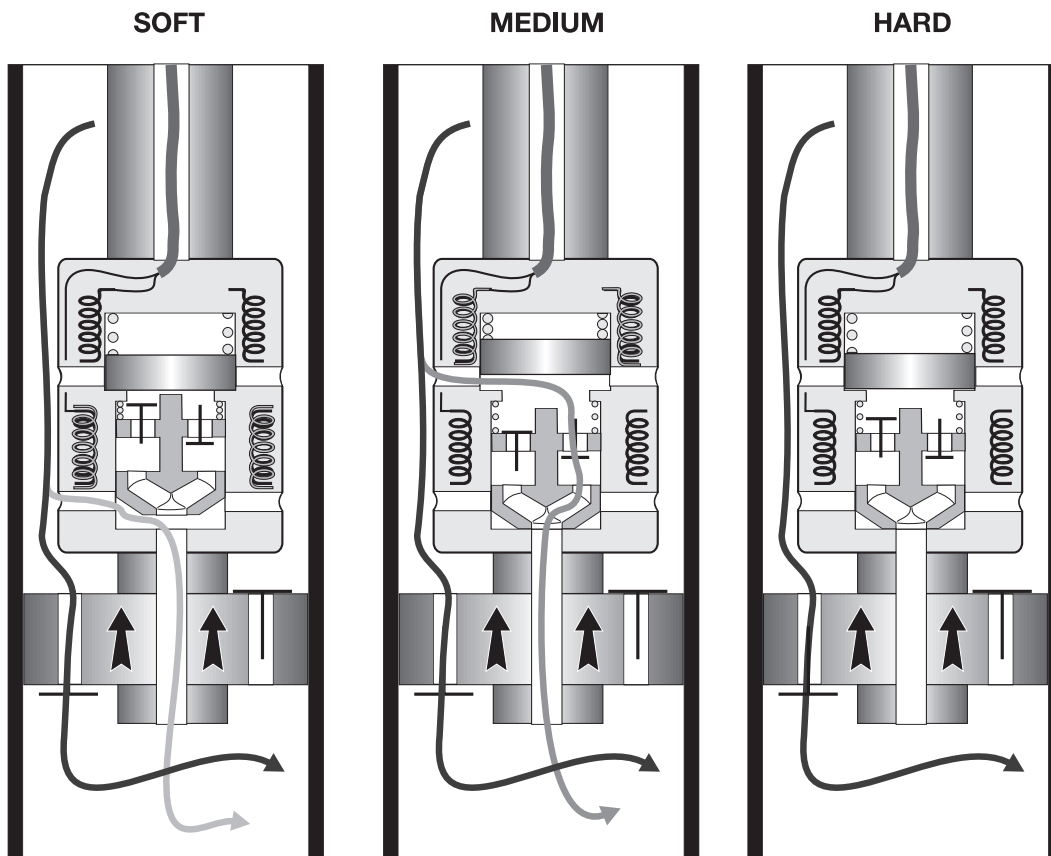

## E31/E32 External Solenoid Damper Operation

The EDC III solenoid operation is identical for both soft and medium settings. The soft solenoid has a larger orifice so more oil can pass through the energized solenoid.

**Soft Setting** = Soft solenoid energized = Maximum oil transfer

**Medium Setting** = Medium solenoid energized = Moderate oil transfer

**Hard Setting** = No solenoids energized = No oil transfer through solenoids

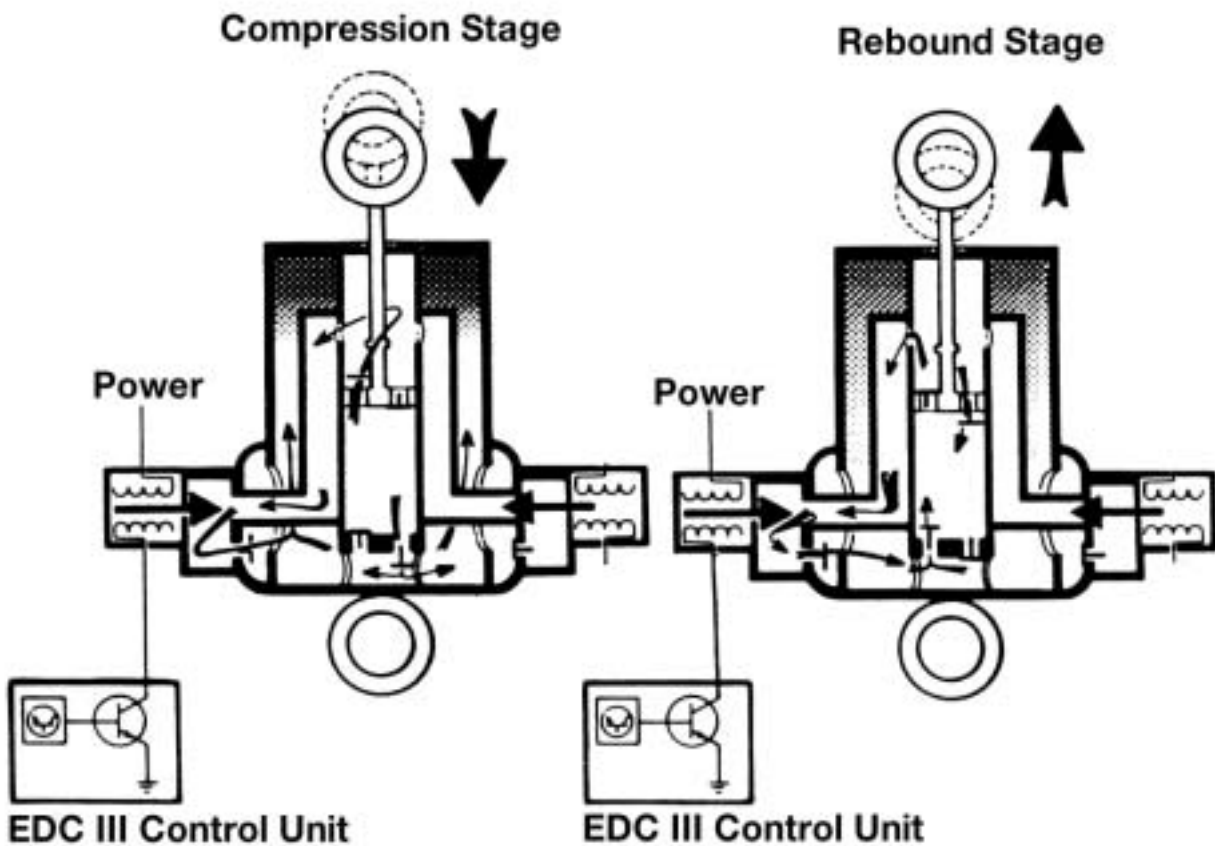

# E38 I-P-O

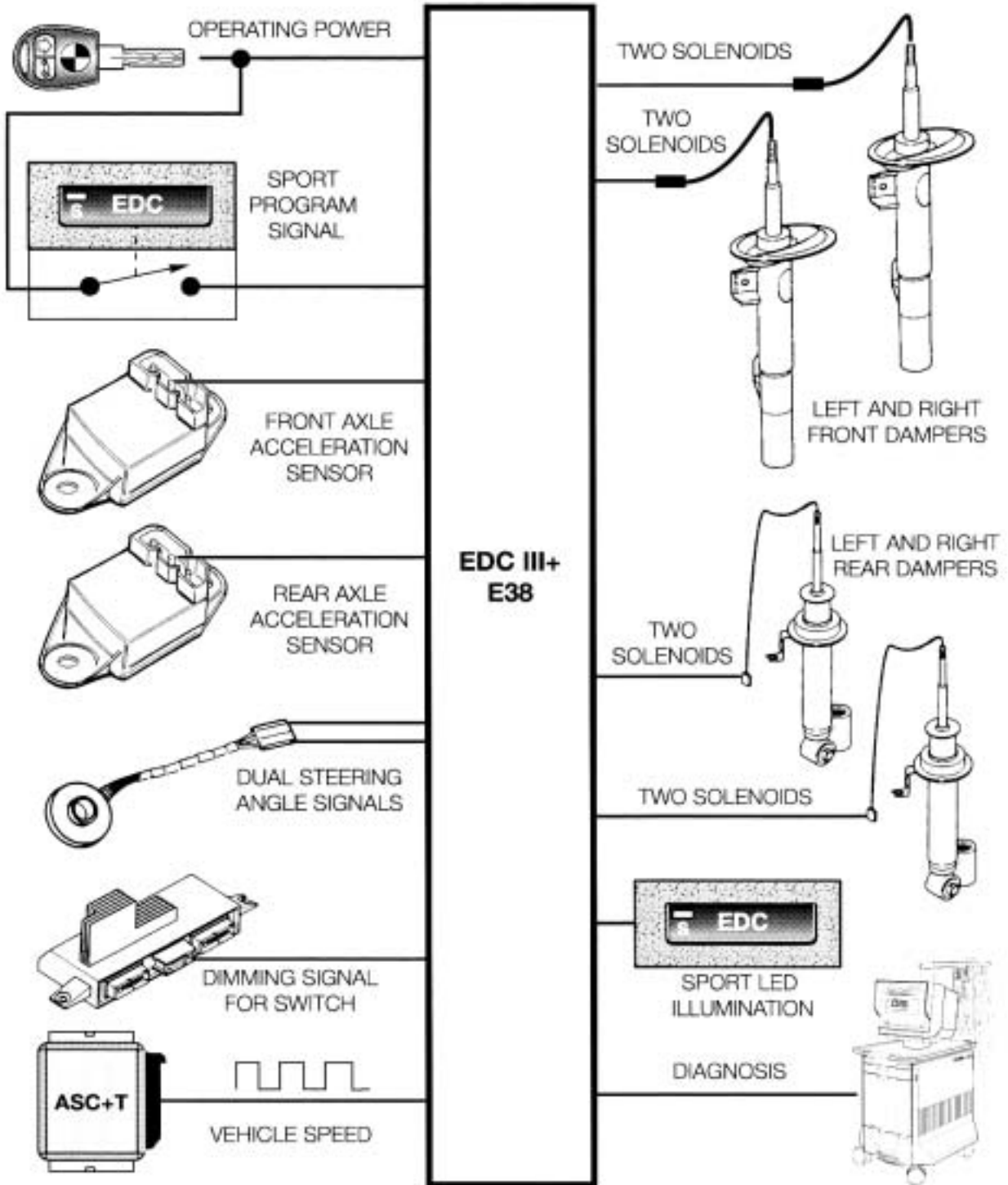

# E31-E32 I-P-O

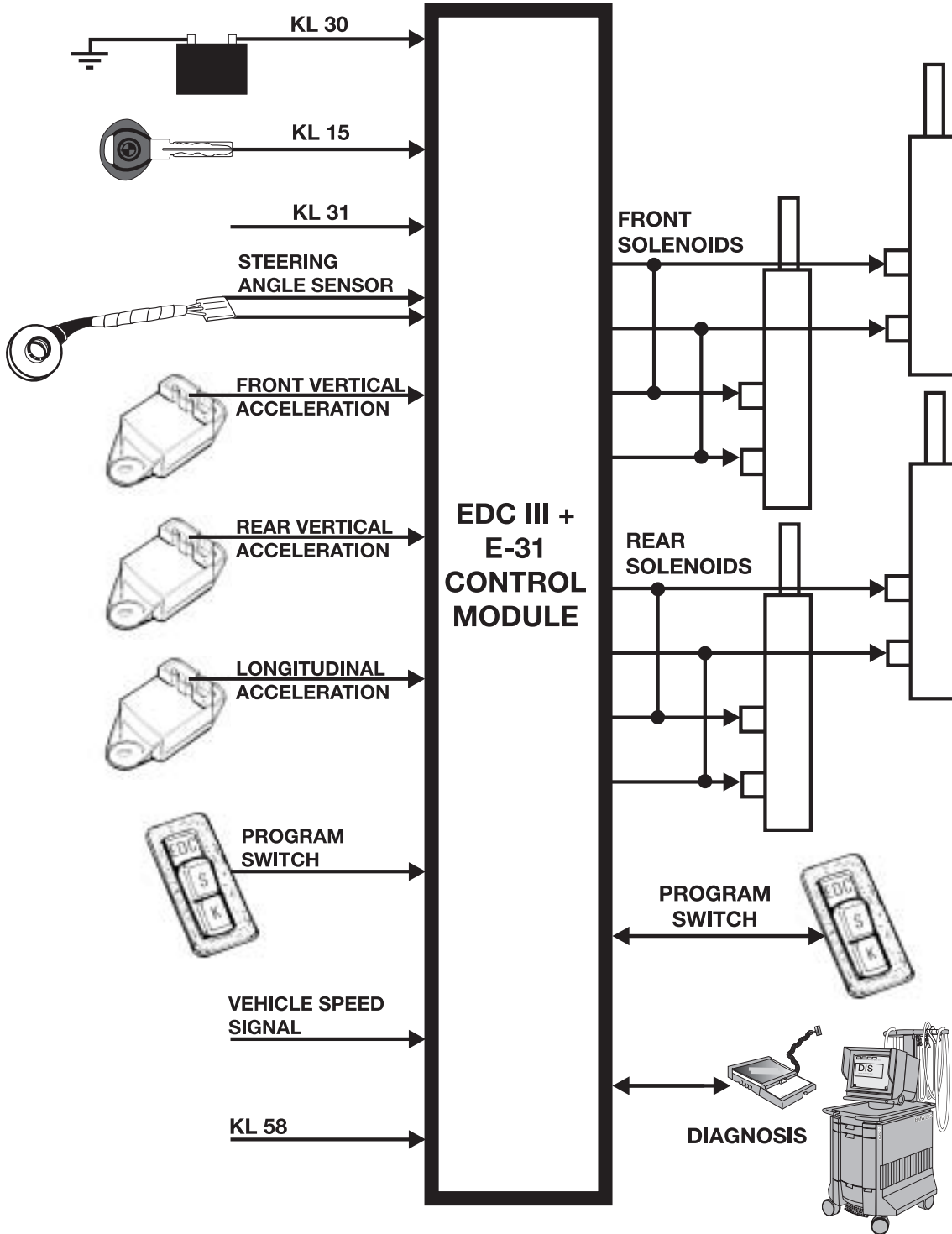

# Electronic Damper Control Functions

## Automatic Load compensation

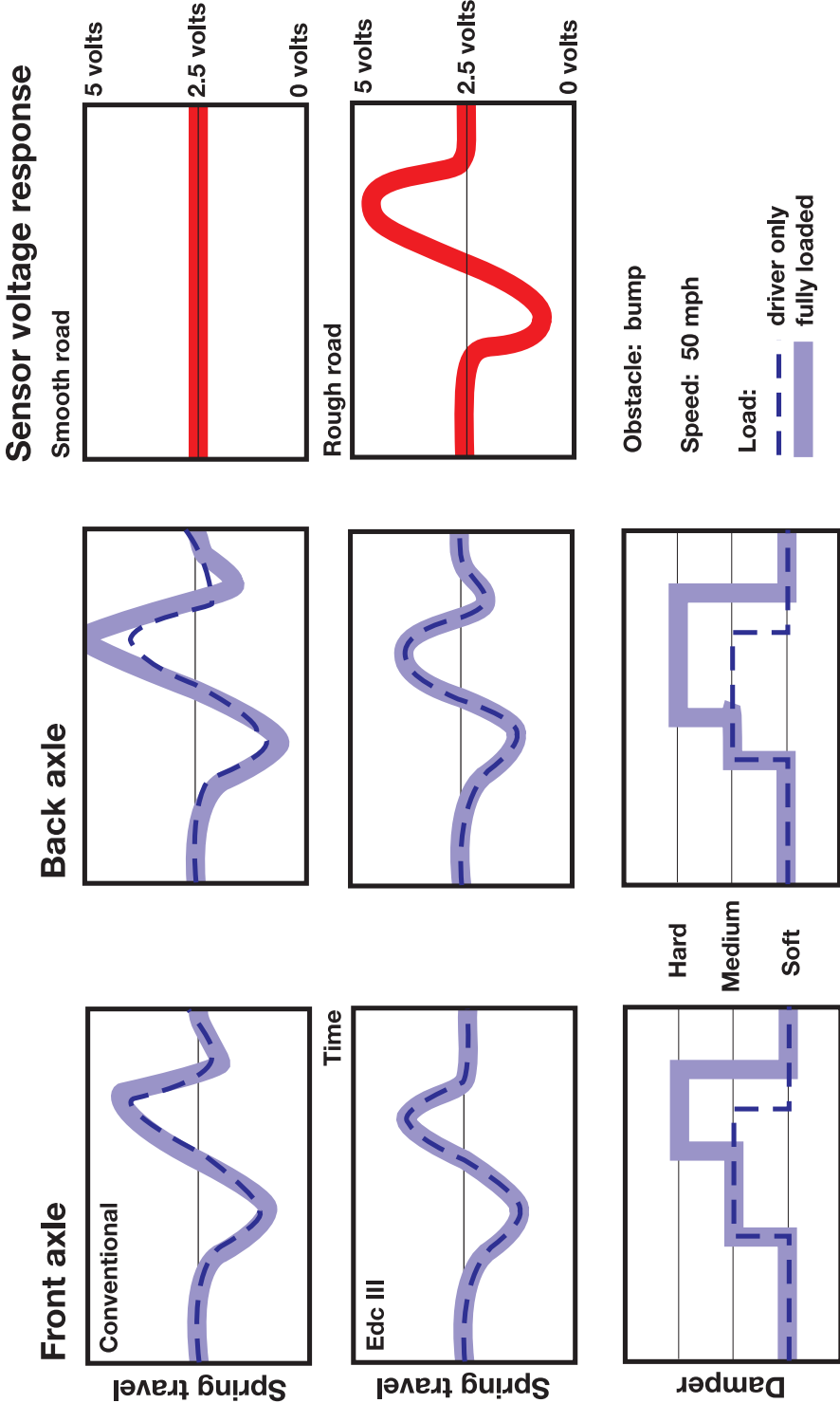

EDC III Ride Program Comparison

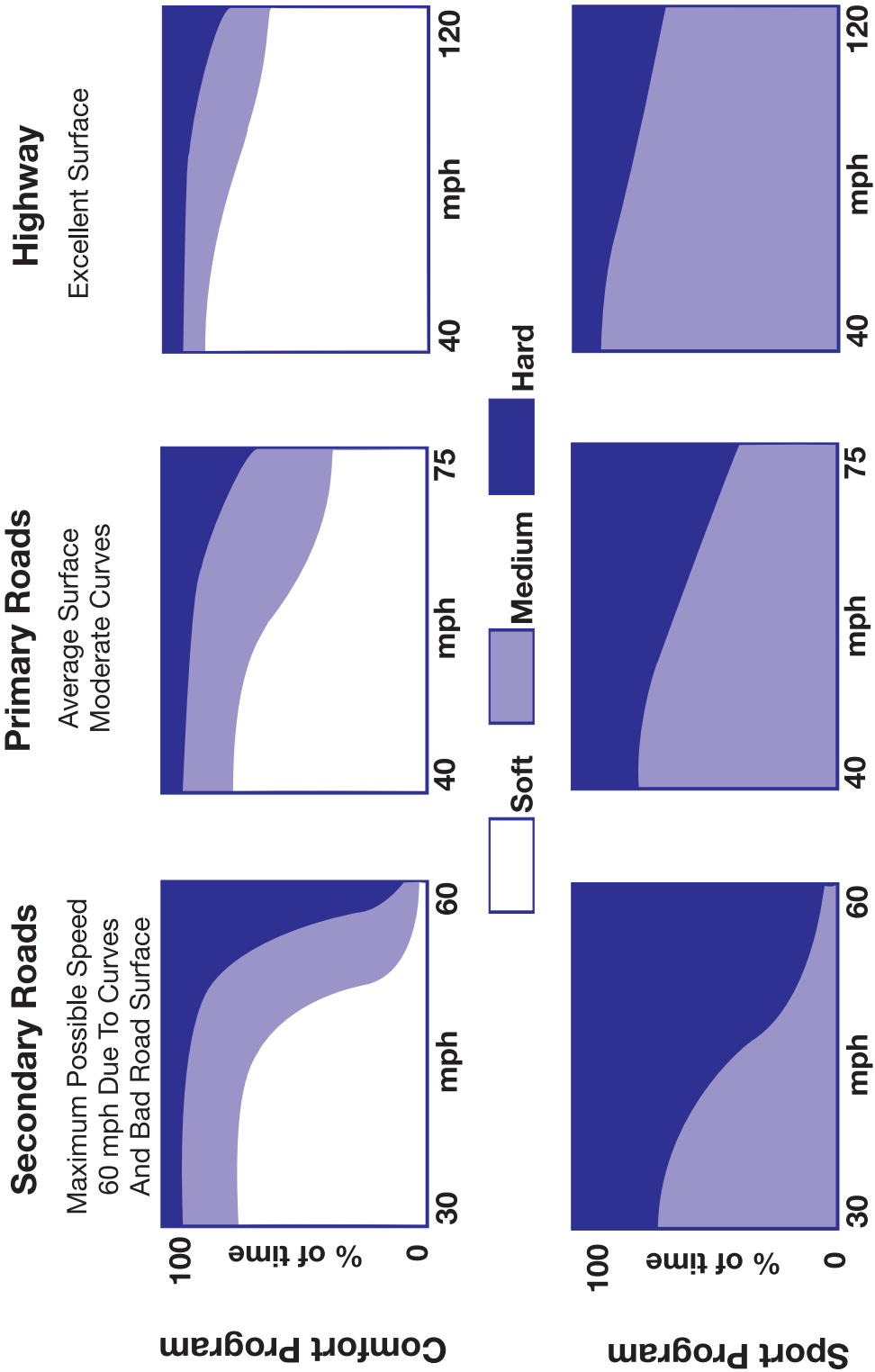

---

## Safety Monitoring

All operating cycles and sensor inputs are checked by the control unit for plausibility and function. Any faults that might occur are stored in the defect memory according to their priority,

In the event of certain faults, the control module selects the "medium" damping setting.

- Steering angle sensor  
e.g. bent wiper in sensor (signals do not match; max. deviation 30deg.) or temporary signal disturbed.
- Steering angle sensor  
e.g. contact difficulties, wiper on conductor of potentiometer, loose contact in conductor.
- Steering angle sensor  
e.g. broken locating pin (sensor always supplies same signal), steering angle sensor not fitted.
- Defective road speed signal  
e.g. break in wire to EDC module.
- Defective acceleration sensor  
e.g. signals not within working range.

If the soft solenoid fails, the medium setting is selected.

If the medium solenoid valve circuit or control module fails, the solenoids are de-energized which results in the hard or fail-safe setting.



## EDC Special Tools E38

**Adapter Harness EDC Shock Solenoids**  
P/N 90 88 6 616 041

Special adapter harness plugs into shock harness for testing purposes.

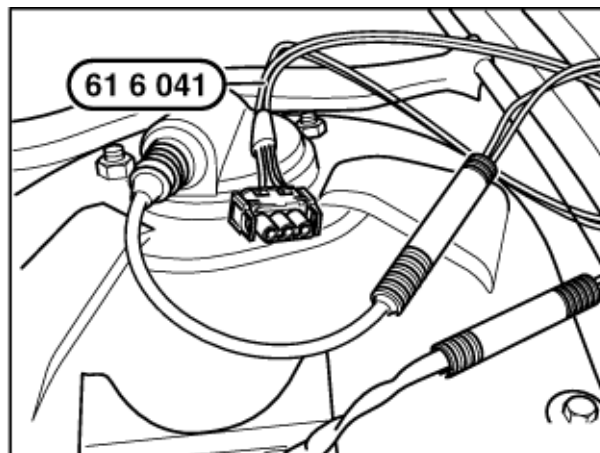

**Shock Assembly Removal Socket**  
P/N 90 88 6 312 210

Special socket for disassembly of shock absorber with new solenoid harness.

